

Thank you very much for using the (Series EA) string grid-connected inverter developed and produced by East Group Co., Ltd. We sincerely hope that this product can meet your demands. We are also looking forward to your suggestions on the performance and functions of our product to facilitate continuous improvement on our product quality.

Please carefully read this manual before using this product. Keep this manual together with other information on the product components and ensure it is easy for relevant personnel to use them.

The contents, pictures, logos and symbols in this manual are all the property of East Group Co., Ltd. Without written authorization, this manual shall not be wholly or partially publicly reproduced by those other than the company's personnel.

Although this manual will be frequently updated and amended, it is inevitable that those described in this manual may be slightly different from the physical product, or mistaken. The users shall refer to the purchased product, and can download the latest version of this manual at [www.eastups.com](http://www.eastups.com), or through the company's sales channel.





## Table of Contents

1. Manual Description.....	1
1.1 Use of manual.....	1
1.2 Readers.....	2
1.3 Effectiveness.....	2
2. Safety Instructions and Considerations.....	3
2.1 Safety instructions.....	3
2.2 Considerations.....	4
2.3 Compliance statement.....	7
3. Product Description.....	6
3.1 Composition of photovoltaic grid-connected system.....	6
3.3 External dimensions and weight.....	6
3.3.1 Appearance description.....	6
3.3.2 Specification of dimensions and weight.....	7
3.4 Technical parameters.....	8
4. Unpacking and Storage.....	13
4.1 Unpacking and inspection.....	13
4.2 Inverter nameplate and identification.....	13
4.3 Inverter storage.....	14
4.4 Safety instructions.....	14
4.5 Installation environment requirements.....	14
4.6 Wall-mounted.....	15
5. Electrical Connection.....	18
5.1 Safety instructions.....	18
5.2 Schematic diagram of electrical connection.....	19
5.3 Cable requirements.....	20
5.4 Electrical connection on DC side.....	20
5.5 Wiring on AC side.....	22
5.6 Protective grounding of case.....	23
5.7 Communication module.....	24
5.8 Kilowatt-hour meter communication and DRM interface.....	25
5.9 Connection of anti-countercurrent kilowatt-hour meter (Optional).....	26
6. Inverter Commissioning.....	27
6.1 Start up.....	27
6.2 Shutdown.....	27
6.3 LED indicator description.....	27
7. Monitoring System.....	29
8. Removal of Common Faults.....	36
9. Appendix.....	37
9.1 Packing List.....	37
9.2 Quality assurance.....	37
9.3 Contact us.....	38











# 1. Manual Description

## 1.1 Use of manual

This manual contains important safety warnings and operating instructions that must be kept in mind during installation, operation and maintenance. The following safety warnings and general information are provided in this manual:

	<b>DANGER!</b> “DANGER” indicates a dangerous condition which will cause death or sever injury if not avoided.
	<b>WARNINGS!</b> “WARNINGS” indicates a dangerous condition which may cause death or sever injury if not avoided.
	<b>CAUTION!</b> “CAUTION” indicates a dangerous condition which may cause mild or moderate injury if not avoided.
	<b>ATTENTION!</b> “ATTENTION” indicates a dangerous condition which may cause property loss if not avoided.
	<b>NOTES</b> “NOTES” indicate the additional information that emphasizes and complements the contents of this manual and also provides the valuable tips on product installation and operation.

The following electrical symbols and marks may also be used in this manual and on the product, and are described as follows:

Symbol	Description	Symbol	Description
	DC	-	Voltage, negative
	AC	+	Voltage, positive
	Grounding	○	Off (power supply)
	Protective grounding		On (power supply)
	Frame or base terminal		Refer to this manual
	Be aware of shock hazard		Be aware of danger
	Be aware of hot surface		Be aware of shock hazard and scheduled energy release (discharge time is marked beside the symbol)

## **1.2 Readers**





The installers and operators of three-phase string photovoltaic grid-connected inverters should read this manual carefully. This manual describes in detail the transportation, installation, operation, maintenance and troubleshooting of the three-phase string photovoltaic grid-connected inverters developed by us.

## **1.3 Effectiveness**

This manual is applicable to EA series three-phase string photovoltaic grid-connected inverters (hereinafter referred to as inverters).

## 2. Safety Instructions and Considerations

### 2.1 Safety instructions

	<p><b>DANGER!</b> High voltage may threaten life and cause death or severe burns.</p> <ul style="list-style-type: none"><li>▲ The photovoltaic grid-connected inverters must be operated by relevant professionals.</li><li>▲ The photovoltaic matrix may produce dangerous voltage after exposure to sunlight.</li><li>▲ When the inverter is operating, do not touch the live components of the photovoltaic system.</li><li>▲ Please pay attention to all safety instructions listed in this manual.</li></ul>
	<p><b>DANGER!</b> Touching the contacts and terminals, etc. inside or connected with the grid or device may cause death or fire due to electric shock!</p> <ul style="list-style-type: none"><li>▲ Do not touch the terminals or conductors connected to the grid circuit.</li><li>▲ Pay attention to all grid connection instructions or safety instructions.</li><li>▲ Make sure to take all safety measures for protecting the low-voltage grid.</li></ul>
	<p><b>DANGER!</b> Damaged equipment or system failure may cause electric shock or fire!</p> <ul style="list-style-type: none"><li>▲ Before operation, visually check whether the equipment is damaged or in other dangerous condition.</li><li>▲ Check whether external equipment and circuit connections are safe.</li><li>▲ Confirm that the equipment is in a safe condition before operation.</li></ul>
	<p><b>WARNINGS!</b></p> <ul style="list-style-type: none"><li>▲ The inverter can be connected to the grid only with approval of the local power company.</li><li>▲ All electrical installations must comply with local electrical installation standards.</li></ul>
	<p><b>WARNINGS!</b> Any unprofessional operation of this product may result in death or serious burns</p> <ul style="list-style-type: none"><li>▲ Only professional electricians or personnel with professional qualifications are available for the electrical operation of this product.</li><li>▲ During maintenance, at least two maintainers must work on site; AC All circuit breakers and DC switches (optional) should be disconnected. Wait at least 10 minutes to ensure the full discharge of the internal energy storage components, and confirm the discharge by a voltmeter.</li></ul>

	<p><b>ATTENTION!</b> Touching or improper operation of printed circuit boards or other electrostatic sensitive elements may cause their damage.</p>
	<p>Avoid unnecessary contact with the circuit board.</p> <p>Follow electrostatic protection regulation and wear an anti-static bracelet.</p>

During the operation of the company's products and equipment, the relevant considerations and special safety instructions provided in this manual must be strictly observed. We do not take any responsibility for the hidden trouble caused by noncompliance with the safety operation requirements or the design standards.

## DECLARATION

We have the right not to provide quality assurance in any of following cases.

- Expiration of the free warranty period for the product and its component;
- Damage caused during transportation;
- Installation, modification or use that does not meet national standards;
- Use in harsh conditions unmentioned in this manual;
- Machine failure or damage caused by installation, repair, alteration or disassembly of the service agency and personnel unacceptable to us;
- Inverter failure or damage due to use of non-standard or non-our parts or software;
- Any design, installation and use unmentioned in relevant international standards;
- Equipment damage caused by abnormal natural environment (force majeure, such as lightning strike, earthquake, fire and storm, etc.).

### 2.2 Considerations

- During installing the PV array, the solar array is covered by a light-tight material, otherwise the solar array will produce high voltage when exposed to the sun's rays.
- The input DC voltage should not exceed 1100V. High voltage may cause damage to the inverter.
- The inverter should be properly transported, stored, assembled, installed, operated and maintained.
- All operation and wiring must be done by a professional electrical or mechanical engineer to ensure that all electrical installations meet electrical installation standards. To ensure safe operation, proper grounding is required and the necessary short circuit protection is provided.
- Before inspection or maintenance, make sure that there is no electricity on DC side and AC side.
- Even if all connections with the inverter have been disconnected, there may still be fatally high voltages in the capacitor of the inverter. Therefore, turn down the inverter and at least wait for 10 minutes before starting inspection, maintenance and other works.
- Fully according to all hazard, warning, and safety information as directed in the installation and operation instructions of this manual.
- As the inverter generates heat during operation, do not touch the heat sink and other hot parts of the inverter, which can avoid burns.

### **2.3 Compliance statement**

The inverter meets NB/T 32004-2018 standard, and 280V default grid overvoltage two-stage protection of China.

### 3. Product Description

#### 3.1 Composition of photovoltaic grid-connected system

The photovoltaic grid-connected power generation system is composed of a photovoltaic module, a photovoltaic grid-connected inverter, a metering device and a distribution system. The solar energy is converted into direct current through the photovoltaic modules, and the direct current is converted into sinusoidal alternating current with the same frequency and phase with the grid by the grid-connected inverts, and then fed to the grid.

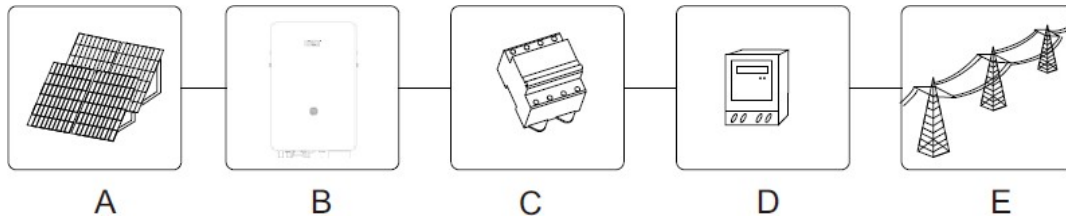

Fig. 1 Photovoltaic grid-connected power generation system

No.	Description
A	Photovoltaic modules
B	EA series photovoltaic grid-connected inverter
C	AC circuit breaker
D	Grid-connected kilowatt-hour meter
E	Public grid

#### 3.2 External dimensions and weight

##### 3.2.1 Appearance description

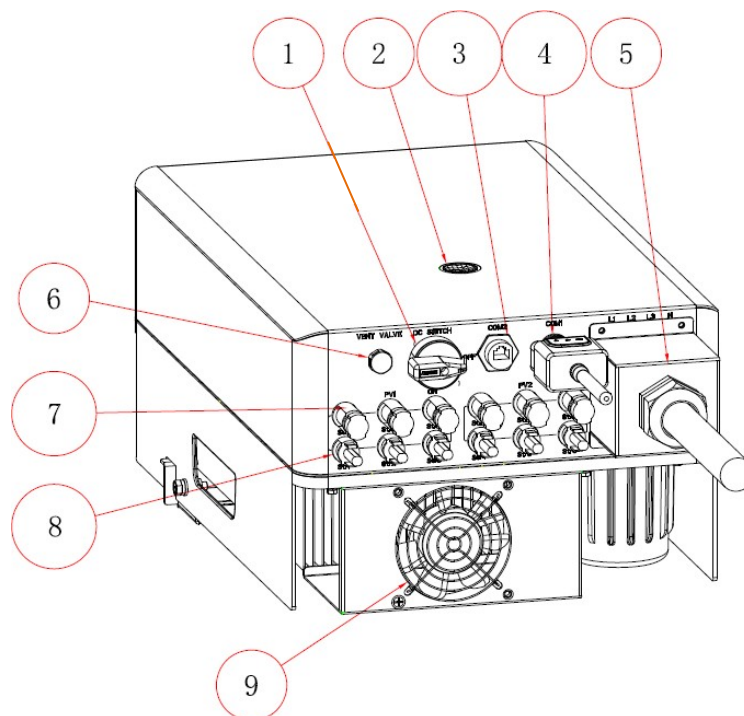

Fig. 3 Inverter appearance description



No.	Description	Remarks
1	DC switch (optional)	Directly control ON and OFF of DC input
2	LED display panel	Display the operating status/communication status of the inverter
3	Kilowatt-hour meter & DRM communications	User kilowatt-hour meter communication and DRM (demand response mode) interface
4	WIFI & GPRS communication terminals	Used to connect to WiFi or GPRS communication modules
5	AC output terminal	Feed the power energy from the inverter, to the grid
6	Breather valve	Prevent condensation and fog and balance the pressure difference inside and outside the case
7	PV+ input terminal	Used to connect the positive terminal of the PV module
8	PV- input terminal	Used to connect the negative terminal of the PV module
9	Cooling fan	Used to cool the inverter

### 3.2.2 Specification of dimensions and weight

Fig. 4 shows the appearance of this product series. The mechanical dimensions are 320mm × 480mm × 215mm (W × H × D), and the weight is about 23kg.

The volume and weight of the chassis are greatly reduced for this inverter series to facilitate handling, movement and installation.

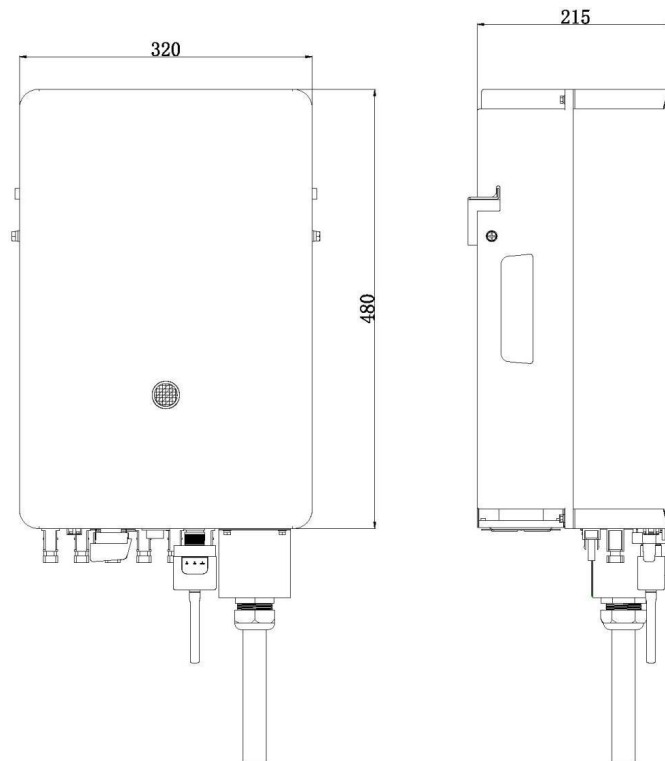

Fig. 4 Appearance and mechanical size of photovoltaic grid-connected inverter

### 3.3 Technical parameters

Table 1: S-series

	EA15KTL-S	EA17KTL-S	EA20KTL-S	EA25KTL-S	EA30KTL-S	EA33KTL-S
<b>Input (DC)</b>						
Maximum input power	22.5kW	25.5kW	30kW	37.5kW	45kW	45kW
Maximum input voltage	1100Vdc					
Grid-connected startup voltage	180Vdc					
MPPT operating voltage range	160~1000Vdc					
Maximum input current	15A/30A	15A/30A	30A/30A	30A/30A	30A/45A	37.5A/37.5A
Maximum short circuit current	20A/40A	20A/40A	40A/40A	40A/40A	40A/60A	45A/45A
MPPT quantity	2	2	2	2	2	2
Maximum number of input string	3(1/2)	3(1/2)	4(2/2)	4(2/2)	5(2/3)	6(3/3)
<b>Output (AC)</b>						
Rated output power	15kW	17kW	20kW	25kW	30kW	33kW
Maximum apparent power	16.5kVA	18.7kVA	22kVA	27.5kVA	33kVA	33kVA
Maximum output current (400V grid)	23.9A	27A	31.8A	39.7A	47.7A	47.7A
Maximum output current (380V grid)	25.1A	28.5A	33.5A	41.8A	50.2A	50.2A
Rated grid voltage	400V/380V,3W+N+PE					
Grid voltage range	320~480V					
Rated grid frequency	50Hz/60Hz					
Grid frequency range	45~55Hz/55~65Hz					
Total current waveform distortion	<3%(rated power)					

Output current DC component	<0.5%In
Power factor	>0.99 (rated power)
Power factor adjustment range	0.8 leading to 0.8 lagging
<b>Efficiency</b>	
Max. efficiency	98.30%
European efficiency	98.10%
<b>Protection</b>	
DC switch	Yes
DC reverse polarity protection	Yes
Detection of insulation impedance to ground	Yes
Leakage current protection	Yes
Output overcurrent protection	Yes
Output overvoltage protection	Yes
Anti-island protection	Yes
DC surge protection	Yes
AC surge protection	Yes
<b>Universal</b>	
Night loss	<1W
Isolation mode	No transformer
Protection grade	IP66
Operating temperature range	-25~+60°C(derated at >45 °C)
Operating humidity range	0~100% (non-condensing)
Cooling method	Air cooling

Maximum operating altitude	4000m (derated at >2000m)	
Bare machine size	320*480*215mm	
Packaging size	410*680*305mm	
Net weight	20kg	22.5kg
gross weight	22.5kg	25kg
<b>Display &amp; Communications</b>		
Display	LED , APP	
Communications	RS485 , WiFi	
<b>Standard</b>		
Safety/EMC/grid connection	LVD EN62109-1/-2 ; EMC EN61000-6-1/-2/-3/-4 ; CEI 0-21 ; VDE 4105 ; EN50549 ; DIN VDE 0126-1- 1 VFR 2019 ; RAE 1165/2020	

Table 2: P-series

	EA15KTL-P	EA17KTL-P	EA20KTL-P	EA25KTL-P	EA30KTL-P
<b>Input (DC)</b>					
Maximum input power	22.5kW	25.5kW	30kW	37.5kW	45kW
Maximum input voltage	1100Vdc				
Grid-connected startup voltage	180Vdc				
MPPT operating voltage range	160~1000Vdc				
Maximum input current	20A/20A	20A/20A	20A/40A	20A/40A	40A/40A
Maximum short circuit current	25A/25A	25A/25A	25A/50A	25A/50A	50A/50A
MPPT quantity	2	2	2	2	2
Maximum number of input string	2(1/1)	2(1/1)	3(1/2)	3(1/2)	4(2/2)
<b>Output (AC)</b>					
Rated output power	15kW	17kW	20kW	25kW	30kW
Maximum apparent power	16.5kVA	18.7kVA	22kVA	27.5kVA	33kVA

Maximum output current (400V grid)	23.9A	27A	31.8A	39.7A	47.7A
Maximum output current (380V grid)	25.1A	28.5A	33.5A	41.8A	50.2A
Rated grid voltage	400V/380V,3W+N+PE				
Grid voltage range	320~480V				
Rated grid frequency	50Hz/60Hz				
Grid frequency range	45~55Hz/55~65Hz				
Total current waveform distortion	<3%(rated power)				
Output current DC component	<0.5%In				
Power factor	>0.99 (rated power)				
Power factor adjustment range	0.8 leading to 0.8 lagging				
<b>Efficiency</b>					
Max. efficiency	98.30%				
European efficiency	98.10%				
<b>Protection</b>					
DC switch	Yes				
DC reverse polarity protection	Yes				
Detection of insulation impedance to ground	Yes				
Leakage current protection	Yes				
Output overcurrent protection	Yes				
Output overvoltage protection	Yes				
Anti-island protection	Yes				
DC surge protection	Yes				
AC surge protection	Yes				
<b>Universal</b>					

Night loss	<1W	
Isolation mode	No transformer	
Protection grade	IP66	
Operating temperature range	-25~+60°C(derated at >45 °C)	
Operating humidity range	0~100% (non-condensing)	
Cooling method	Air cooling	
Maximum operating altitude	4000m (derated at >2000m)	
Bare machine size	320*480*215mm	
Packaging size	410*680*305mm	
Net weight	20kg	22.5kg
gross weight	22.5kg	25kg
<b>Display &amp; Communications</b>		
Display	LED , APP	
Communications	RS485 , WiFi	
<b>Standard</b>		
Safety/EMC/grid connection	LVD EN62109-1/-2 ; EMC EN61000-6-1/-2/-3/-4 ; CEI 0-21 ; VDE 4105 ; EN50549 ; DIN VDE 0126-1- 1 VFR 2019 ; RAE 1165/2020	



**NOTE: The above data is for reference. In case of any change, the actual data shall prevail.**

## 4. Unpacking and Storage

### 4.1 Unpacking and inspection

Although the product has been rigorously tested and inspected before shipping, damage may be caused during shipping, please check the following items before signing for the product:

- Check for obvious damage upon receipt of the product.
- After unpacking, check the equipment for good condition.
- Check according to the packing list that the shipped components are complete and comply with the order.

Contact the transport company or us directly if any damage is found. Please provide a photo of the damage and we will provide you with the fastest and best service.

Please keep the original packaging of the inverter. When the inverter is not in use, please store the inverter in the original packing.

### 4.2 Inverter nameplate and identification

The user can identify the inverter through the nameplate. The nameplate is attached on the side of the inverter to indicate the model, important parameters, certification mark and production location of the inverter, and must not be damaged or covered.

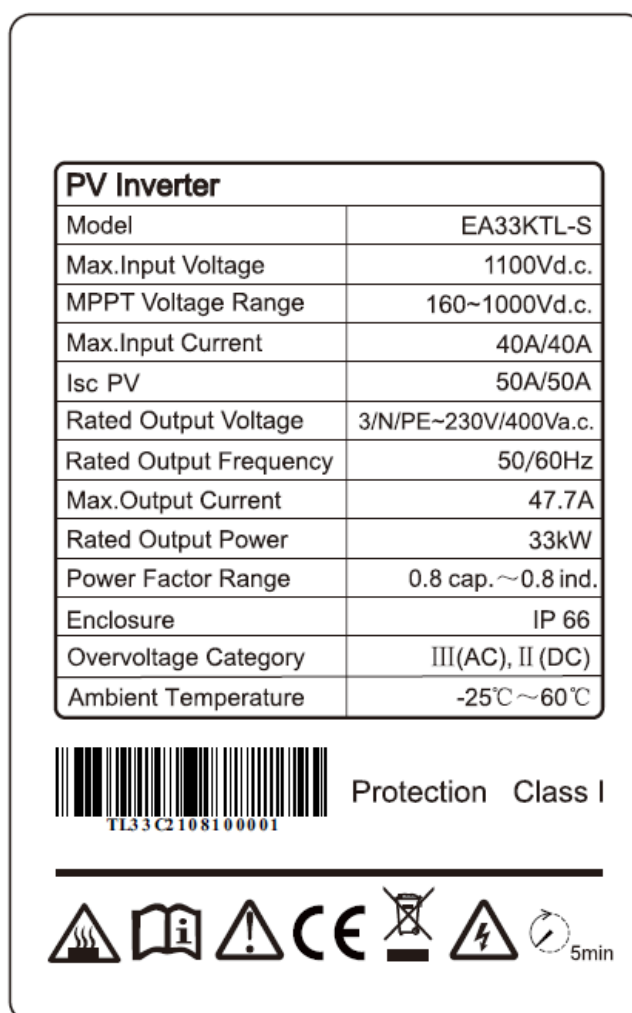



Fig. 5 Inverter nameplate (\* The picture is for reference only, subject the actual nameplate!)

### 4.3 Inverter storage

If the inverter is not put into operation immediately, store the inverter under specific environmental conditions:

- Repack the inverter in the original packing, keeping desiccant.
- Seal the packing by a packaging tape.
- Store the inverter in a clean, dry environment and protect the inverter against dust and moisture.
- Maintain at  $-30^{\circ}\text{C} \sim +85^{\circ}\text{C}$  temperature and 0 - 95% relative humidity without condensation in the storage environment.
- If multiple inverters are stacked, maximum stacking layers should not exceed 5.
- Avoid corrosive substances that may corrode the inverters.
- During storage, check the inverter regularly and change the packaging materials timely if it is damaged by insects and rats.
- Do not tilt or turn the packing upside down.
- After long-term storage, fully check and test the inverter by professionals before use.

### 4.4 Safety instructions

	<b>DANGER! Wrong installation location may result in fire or explosion!</b>
	<ul style="list-style-type: none"><li>• Do not install the inverter on flammable construction materials.</li><li>• Do not install the inverter near any stored flammable materials.</li><li>• Do not install the inverter near any explosive locations.</li></ul>

### 4.5 Installation environment requirements

In order to ensure the proper operation of the inverter, follow the following installation environment requirements:

1. The inverter is an outdoor inverter with IP65 waterproof rating. The installation position should be cool and ventilated without exposure of the inverter to direct sunlight. Otherwise, it is possible to cause extra temperature rise in the inverter, resulting in derating operation of the protection circuit, and even shutdown due to over-temperature.
2. As rain and snow have major impact on the service life of the inverter, please install the inverter at the location where rain and snow cannot affect, or if necessary, shelter the installation location.
3. As ventilation and heat dissipation is very important to the inverter, do not install the inverter in the closed environment, otherwise, the inverter may stop, even be damaged due to over-temperature.
4. During installing, fully consider the weight of the inverter (see 3.4 technical parameters for the weight). The installation location should be able to support the weight of the inverter for a long time. Vertical installation is allowed only, horizontal installation is strictly prohibited, and vibration is unacceptable in the installation location.
5. Install the inverter away from residential areas as much as possible, as noise may be caused during operation. Ensure the convenient observation of the LED lamps in the installation location. Reserve enough space around the inverter to ensure ventilation, heat dissipation, installation and maintenance, and safety passage.
6. As the inverter may be damaged, and cause fire in salty areas, do not install the inverter outdoors salty areas.



A salty area refers to an area which is less than 500m from the coast or affected by sea breeze. The areas affected by sea breezes vary with meteorological conditions (such as typhoons, seasonal

	<b>ATTENTION</b>
	The ambient temperature range should be between -25°C and +60°C. If the temperature exceeds the range, the output power of the inverter may be affected.

winds) or topographical conditions (dykes, hills).

	<b>ATTENTION</b>
	The ambient relative humidity range should be between 0% and 100%.

#### 4.6 Wall-mounted

Notes: The inverter should be installed vertically or at backward inclination angle of not more than 15°, lateral inclination and horizontal installation should not be allowed, and the wiring area should face down.

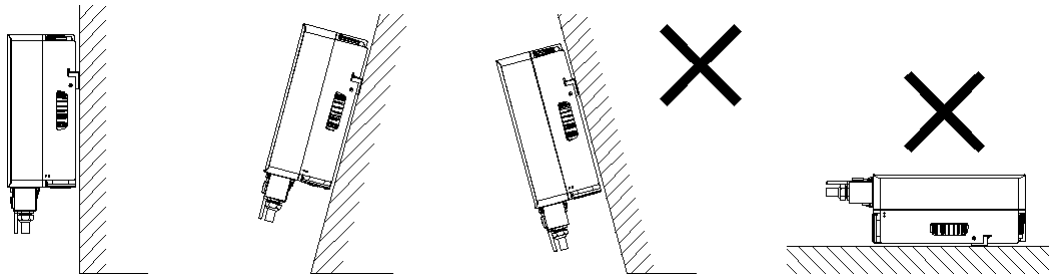

Fig. 6

In order to ensure good heat dissipation and convenient disassembly, the minimum clearance around the inverter shall not be less than the following values (Fig. 7).

- Above .....800mm
- Below .....600mm
- Front .....1000mm
- Sides .....300mm

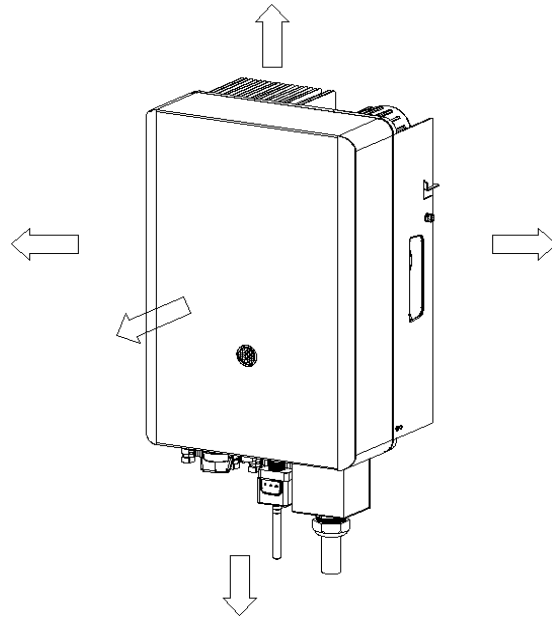

Fig. 7

Installation steps:

1. Mark the hole positions on the wall where the inverter will be installed according to the hole positions on wall mounting bracket (Fig. 8). Drill suitable mounting holes by an electric drill at the marked position according to the specifications of the expansion bolts to be used, and then secure the wall mounting bracket to the wall through the expansion bolts with a torque of at least 30Nm for the fastening nut (Fig. 9). It is recommended to use M6x50 expansion bolts.

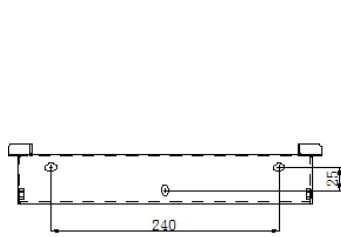

Fig. 8

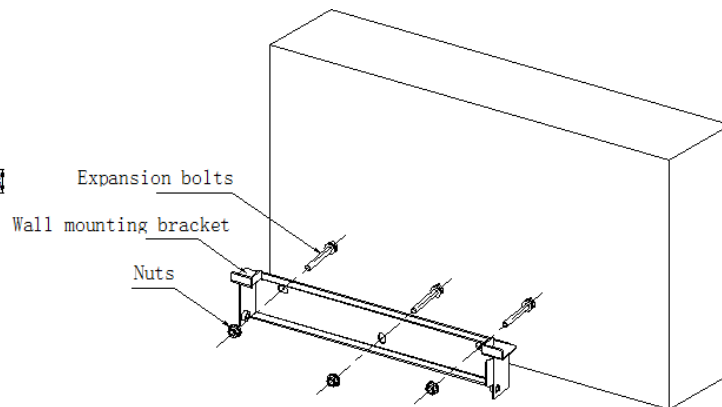

Fig. 9

2. Hang the inverter hanger vertically onto the wall mounting bracket (Fig. 10). Fasten the wall mounting bracket and the inverter hangers by M5 bolts on the left and right sides of the wall mounting bracket (Fig. 11).

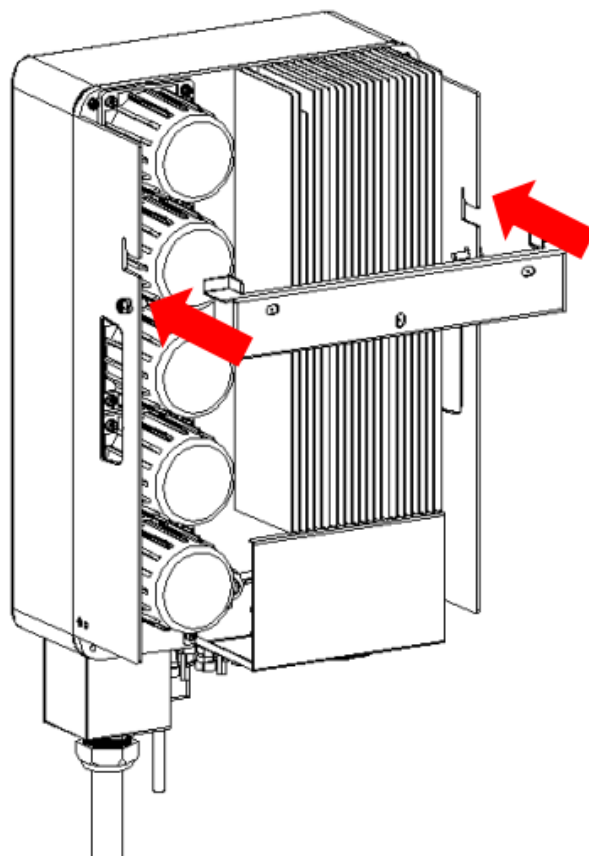

Fig. 10

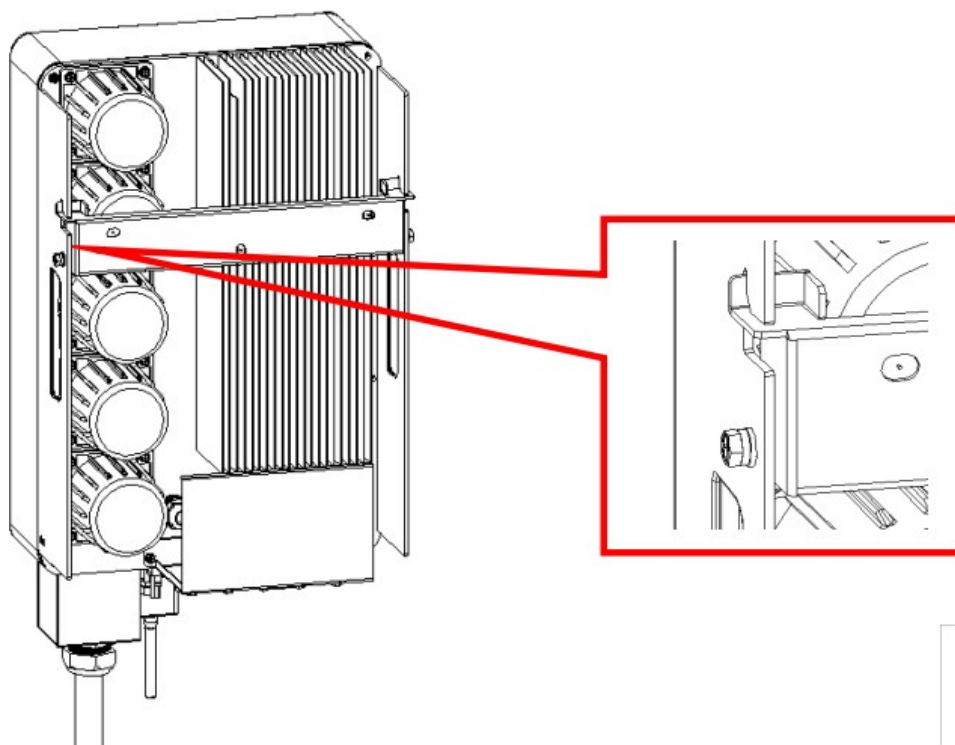







Fig. 11

## 5. Electrical Connection

### 5.1 Safety instructions

	<p><b>DANGER!</b></p> <p>Incorrect wiring may result in life-threatening and irreparable damage to the inverter and wiring must be done under the guidance of a professional.</p> <p>Before wiring, make sure to disconnect the circuit breaker on the AC side of the inverter, and the circuit breaker on DC side (optional) and hang a warning sign .</p>
	<p><b>WARNINGS!</b></p> <p>The voltage and current of the inverter must be considered at all times when the photovoltaic system is designed (See Section 3.4).</p>
	<p><b>WARNINGS!</b></p> <p>Make sure that the electrical connection design meets national and local standards.</p>
	<p><b>ATTENTION</b></p> <p>The protection grade of this inverter is IP66, please use the wiring terminals provided by us, otherwise the protection graded of the inverter may be reduced</p>
	<p><b>ATTENTION</b></p> <p>All wiring must be firm and reliable and insulation must be protected.</p>
	<p><b>ATTENTION</b></p> <p>The inverter can be connected with to the grid only with the approval of the local power department.</p>

## 5.2 Schematic diagram of electrical connection

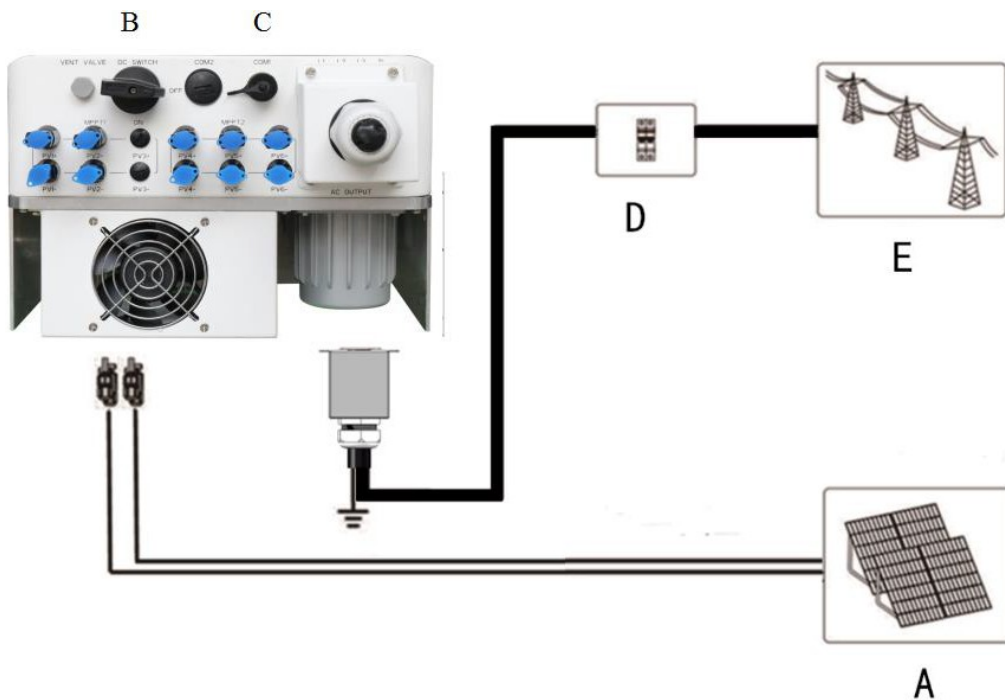



Fig. 13 Schematic electrical connection diagram of inverter

The electrical connection of the inverter includes DC side electrical connection, AC side electrical connection and communication module connection.

No.	Item	Description
A	Photovoltaic array	The inverter features two-channel MPPT, see Section 3.4 Technical Parameters for string input quantity, string open-circuit voltage and maximum operating current limit values.
B	DC switch (optional)	The user is recommended to choose a DC switch according to the use environment, which can directly control the ON and OFF of the DC input.
C	Communication module	Used to connect WiFi or GPRS communication module
D	AC circuit breaker	The user must connect the external AC circuit breaker as a protection device. The user is recommended to select the circuit breaker according to maximum output voltage and current. PE protection wire must be grounded reliably. An independent circuit breaker is used for each inverter, and multiple inverters cannot share the same circuit breaker.
E	Power grid	Rated grid voltage is 3N~380/400V.

	<b>ATTENTION</b>
	Do not connect the load between the inverter and the circuit breaker.

### 5.3 Cable requirements

The inverter is only equipped with waterproof terminals in its package. The user may select appropriate cables according to the following suggestions.

Suggested cable specifications:

Cable	Cable size (mm <sup>2</sup> )
PV input end	4~6mm <sup>2</sup> wire diameter recommended
AC output phase L1	10mm <sup>2</sup> wire diameter recommended for 20-25 kW 16mm <sup>2</sup> wire diameter recommended for 30-33KW
AC output phase L2	10mm <sup>2</sup> wire diameter recommended for 20-25 kW 16mm <sup>2</sup> wire diameter recommended for 30-33KW
AC output phase L3	10mm <sup>2</sup> wire diameter recommended for 20-25 kW 16mm <sup>2</sup> wire diameter recommended for 30-33KW
AC output phase N	10mm <sup>2</sup> wire diameter recommended for 20-25 kW 16mm <sup>2</sup> wire diameter recommended for 30-33KW
Ground cable	6~8mm <sup>2</sup> wire diameter recommended

### 5.4 Electrical connection on DC side

	<b>DANGER!</b>
	<p>Cover the PV panel with a light-tight material or disconnect the DC side isolation switch before electrical connection (there may be fatal high voltage between the PV input terminal and the isolation switch).</p>

	<b>WARNINGS!</b>
	<p>This product is a non-isolated inverter, the positive and negative terminals of the photovoltaic panel cannot be grounded, and otherwise it is possible to cause earth impedance fault, and the failure and even damage to the inverter.</p>

	<b>ATTENTION</b>
	<p>It must be considered in the design of PV array that the maximum open circuit voltage of each PV string shall not exceed 1100V and the short circuit current of each PV string shall not exceed 20A.</p>

We provide the inverter with DC connection terminals. Please assemble the DC cable selected in accordance with the above requirements to the connector by following the steps below. During

assembling, connect the cable with positive terminals with same color and mark them; connect the cable with negative terminals with same color and mark them; For example, in general, connect the positive terminals with the red cables and connect the negative terminals with black cables.

As shown in Fig. 14: upper: PV+ , lower: PV-



Fig. 14

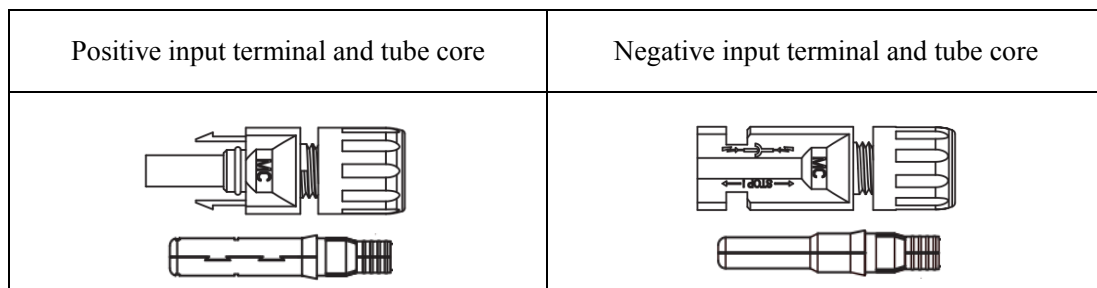

Fig. 15

➤ Wiring step on DC side:

1. Strip the insulating layer of the DC cable by about 8mm to expose the copper conductor. Insert the copper conductor into the metal tube core of the connector and press it down with crimping pliers (Fig. 16)

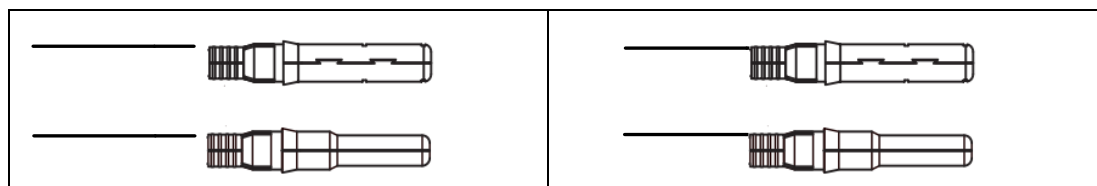

Fig. 16

2. Loosen the terminal cover and pass the cable through the terminal cover. Insert the tube core into the wiring slot until sound indicates proper wiring. Tighten the terminal cover (Fig. 17)

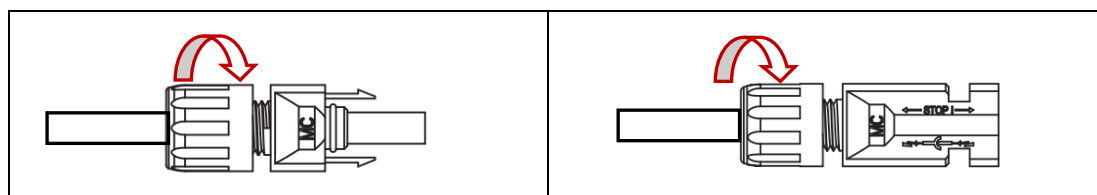





Fig. 17

3. Use a voltmeter with a DC voltage range of more than 1200V to check whether the cable connection polarity of the photovoltaic array is correct and ensure the open-circuit voltage meets the specifications. When the ambient temperature is higher than 10 °C, the open circuit voltage of the photovoltaic array cannot exceed 85% of the maximum DC voltage of the inverter. Otherwise, the photovoltaic array voltage may exceed the maximum input voltage of the inverter at low temperature, causing damage to the inverter.
4. Disconnect the DC switch and connect the PV input cables to the inverter respectively.

## 5.5 Wiring on AC side

	<b>WARNINGS!</b>
	Make sure that the electrical connection design meets national and local standards.

	<b>WARNINGS!</b>
	The non-charged metal parts in the photovoltaic power generation system, including photovoltaic panel support and the metal shell of the inverter, shall be reliably grounded, and the grounding electrode shall meet the standard requirements.

	<b>ATTENTION</b>
	There is a second ground port on the right side of the inverter according to EN50178 requirements, which is connected by M6x12 combination screws with a flat washer or a spring washer.

### ➤ Wiring step on AC side:

1. Pass the cable with appropriate length through the waterproof terminal cover. The ground and neutral wire are longer than the live wire. Strip the insulating layer of the cable by about 10mm (Fig. 18)

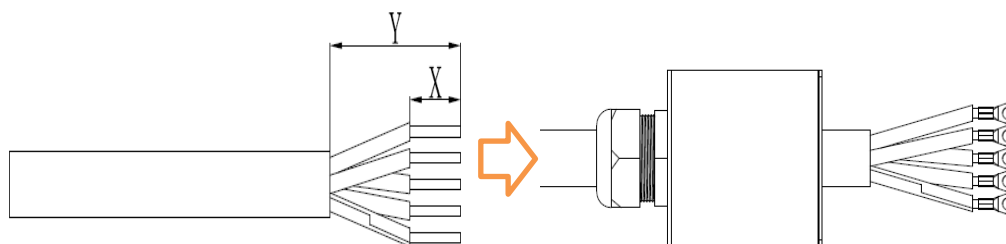

Fig. 18

2. The inverter has phase sequence self-adaption function, the sequence of three phase lines L1, L2 and L3 can not differentiated. Use a screwdriver to fix L1, L2, L3, N and PE wires to the corresponding AC terminals, and ensure that PE wires are grounded reliably (Fig. 19).



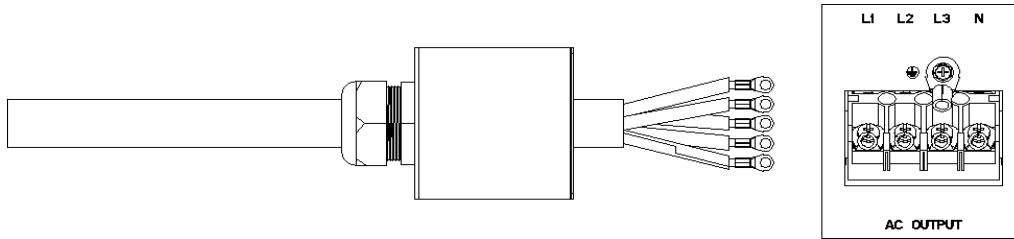

Fig. 19

3. Tightly lock the inverter case and the AC output terminal housing by using M4x10 screws.

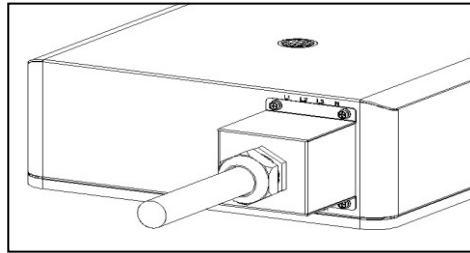





Fig. 20

	<b>ATTENTION</b>
	Once the AC output cable is connected, make sure to timely tighten the waterproof cover and waterproof joints to avoid rain erosion.

### 5.6 Protective grounding of case

	<b>ATTENTION</b>
	The PE of the AC output interface is only used as the equipotential connection point of the protective grounding and cannot be used as the protective grounding point of the case.

	<b>DANGER!</b>
	Do not connect N-wire to the case as a protective grounding wire, otherwise it is possible to cause shock hazard.

A protective grounding hole is formed at the bottom of the inverter. The user must ground the inverter through the grounding hole, and fix by M6\*12 screws (Fig. 21)

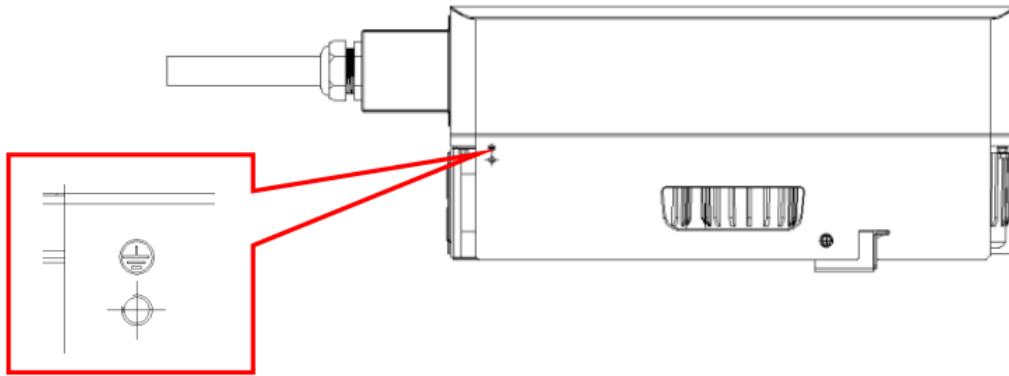



Fig. 21

	<b>ATTENTION</b>
	<p>According to NB/T32004, the residual current protection limit is divided into two types: continuous residual current and residual current mutation. Different limits and protection action time are used for them.</p> <p>There is an integrated residual current detection unit inside the inverter, which can distinguish fault-caused residual current from the residual current caused by photovoltaic panel and parasitic capacitance. When the residual current value is detected to be greater than the allowable value, the inverter will be quickly disconnected from the grid to meet the residual current monitoring and protection requirements of NBT32004.</p> <p>Since the inverter has a high-precision residual current detection device, it is not recommended to install a leakage protection switch in the system. If the leakage protection switch must be installed between the inverter output and the grid for some special reason, please install a Type B leakage protection switch above 300mA. If multiple leakage protection switches are installed in the system, it is forbidden to share the neutral wire; otherwise the leakage protection function may be mistakenly triggered, resulting in switch tripping.</p>

### 5.7 Communication module

Connect the communication module to the COM1 communication port at the bottom of the case and tighten the fastening nut (Fig. 22).

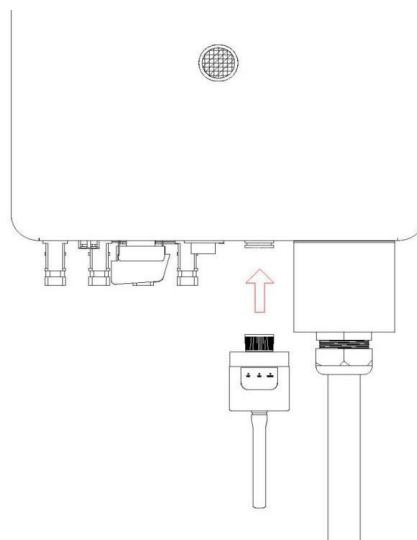

Fig. 22

## 5.8 Kilowatt-hour meter communication and DRM interface

Insert RJ45 connector for kilowatt-hour meter communication and switching input into the COM2 connector at the bottom of the case;

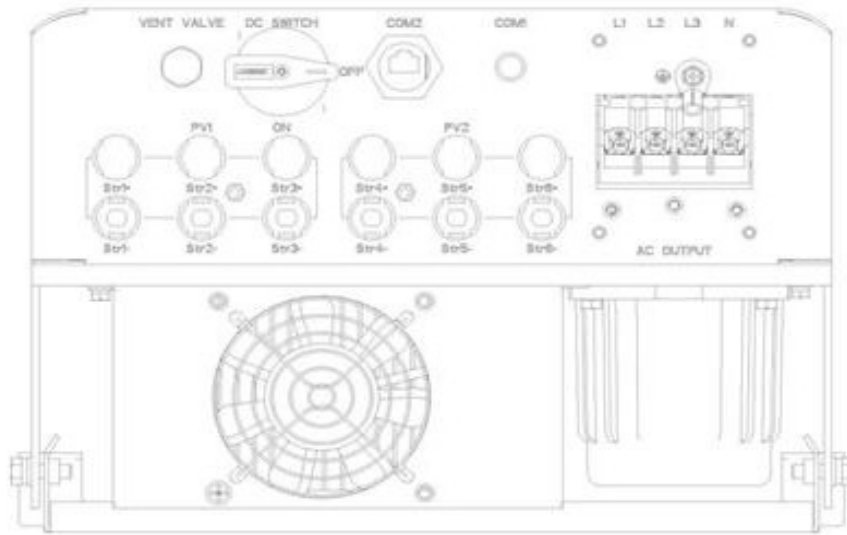
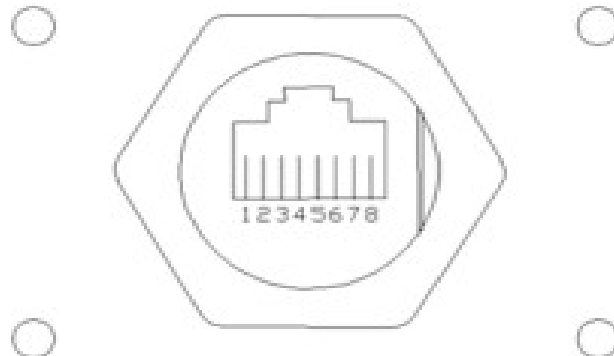

Fig. 23

The following figure shows the enlarged view of the kilowatt-hour meter communication interface and DRM communication interface and the pin number.



The kilowatt-hour meter interface (COM2) is described as follows:

Pins	1	2	3	4	5	6	7	8
<b>Definition</b>	Vcc-5V	RS485-B	RS485-A	GND	Empty	Empty	Empty	Empty

RS485 communication interfaces A and B of the kilowatt-hour meter are connected to pin 8 and pin 6 of the COM2 respectively to realize the communication between the inverter and the kilowatt-hour meter.

	<b>ATTENTION</b>
	<p>When the external network cable is not connected to the COM2, make sure the waterproof cover is secure.</p> <p>Install the waterproof terminals to ensure water resistance of the inverter when the external network cable is connected to the COM2 interface.</p>

## COM2 Wiring

1. Pass the cable through the waterproof terminal, press down the RJ45 connector with a crimping tool, and insert the connector into the waterproof terminal housing.

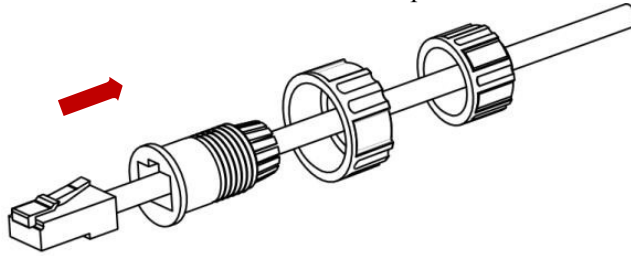

2. Insert the RJ45 connector into the RJ45 port at the bottom of the converter case and tighten the nuts.

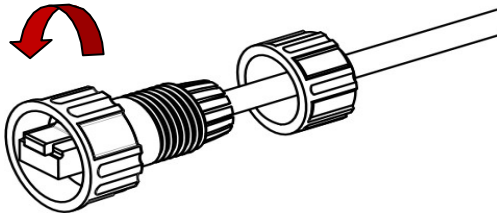

3. Tighten the sealing nut on the tail of the waterproof terminal.

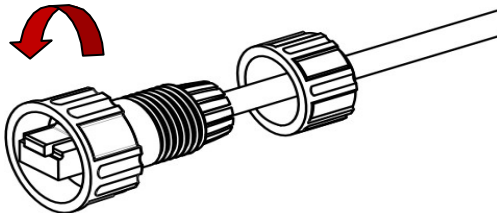

## 5.9 Connection of anti-countercurrent kilowatt-hour meter (Optional)

The inverters with anti-countercurrent functions allow power regulation to prevent energy from entering the grid. Please contact our sales staff for specific functions and equipment selection.

## 6. Inverter Commissioning

### 6.1 Start up

1. Complete the wiring for AC/DC sides of the inverter and the PV array according to the above instructions;
2. Before starting the inverter, check:
  - 1) Whether the inverter is firmly installed, and whether the installation environment is convenient for operation and maintenance.
  - 2) Whether the communication module is connected correctly
  - 3) Whether the AC circuit breaker meets the electrical specifications and is installed correctly
  - 4) Whether the electrical wire is connected reliably, whether the live conductor has been insulated and sealed to ensure safety
  - 5) Whether safety signs and warning labels are eye-catching and clearly visible
  - 6) Whether the grid voltage and DC voltage meet the requirements of the inverter;
3. Close the circuit breaker on the AC side;
4. Close the DC switch of the inverter. If the input voltage is within the required range, the green LED indicator light will light up and blink, and the inverter will start detection.
5. When the light environment conditions meet the working requirements of the inverter, the inverter will automatically start and output power to the grid while the green LED indicator light is always on.
6. When the inverter successfully outputs the power to the grid, the inverter automatically runs without manual control.
7. In case of a fault, the inverter will shut down automatically, and the red LED indicator will light up. For the description of LED indicator, please refer to Section 6.3. The inverter will restart up and run automatically after the fault condition is removed.

### 6.2 Shutdown

1. The inverter will automatically shut down when the light is not enough to keep its operation.
2. In case of a fault, the inverter will automatically display the fault code. If the user needs emergency shutdown, the AC circuit breaker or the DC switch (optional) on the inverter can be directly disconnected.

### 6.3 LED indicator description

During the operation of the inverter, the working status and communication status of the inverter can be checked through the LED indicator on the panel (as shown in Fig. 23), as follows:

LED	Display status	Description
	<b>Green, always on</b>	The inverter is connected to the grid for power generation
	<b>Green, flickering every 1 second</b>	The inverter is waiting to be connected to the grid or started
	<b>Red, always on</b>	Inverter failure
	<b>Red, fast flickering every 0.2 seconds</b>	Power grid failure

<b>Red, slow flickering every 1 second</b>	PV input failure
<b>Yellow, always on</b>	The inverter gives an alarm, but does not stop, still supplies the power to the grid

Special note: If the LED is white, it indicates that the program is being upgraded. Please do not perform any operation until the program upgrade is completed.

## 7. Monitoring System

This series of inverters doesn't have an LCD display screen, therefore the wireless communication module is required to view the running state. Please refer to section 6 for the installation of wireless communication module. After installing the Wi-Fi communication module, users can download a mobile App to monitor the running state of the whole PV system.

### 7.1 Professional Edition App

The user can view the running status of the inverter, configure the operational parameters and upgrade the software via the professional App. Professional App is recommended for professionals, operation and maintenance personnel.

#### 7.1.1 Software Installation

Search "solarmanPro" in Apple Store to download the App for iPhones. Search "solarmanPro" in Google Play to download the App for Android phones.

#### 7.1.2 Registration & Login

**Registration:** Enter App after downloading "solarmanPro". Click on [Free Account], then enter registration information and follow [Next] procedures until [Applied], as shown below.

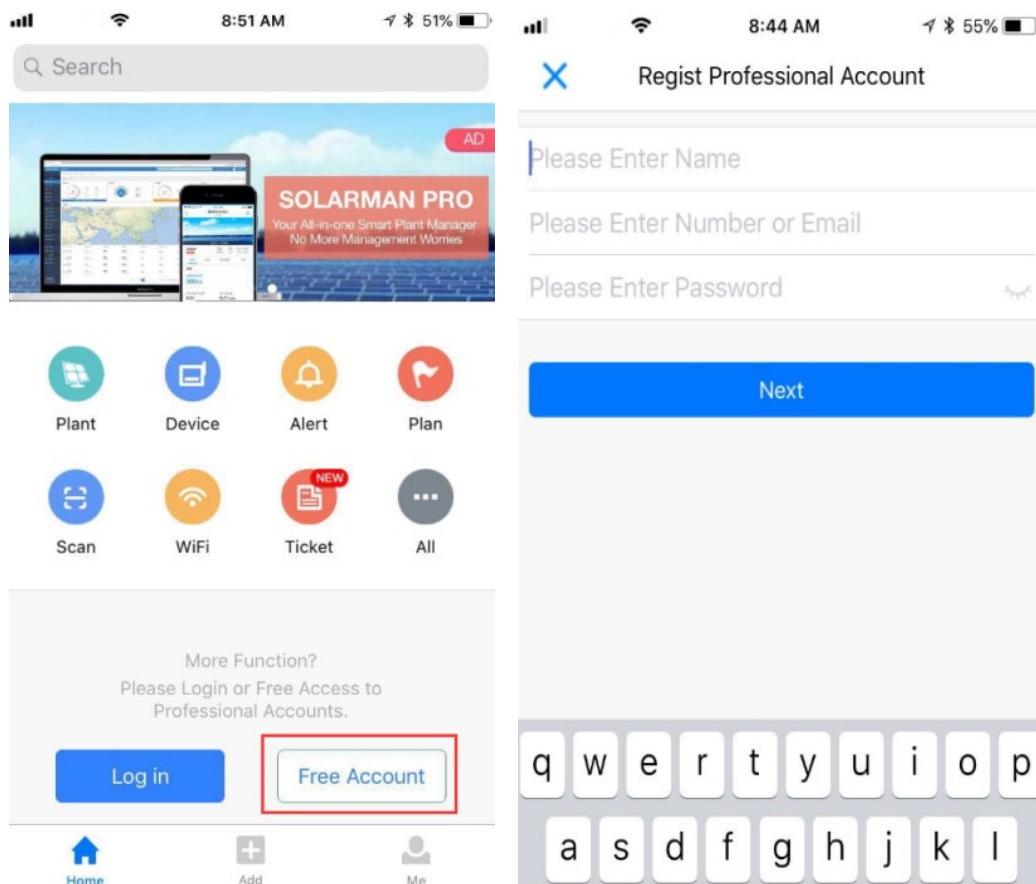

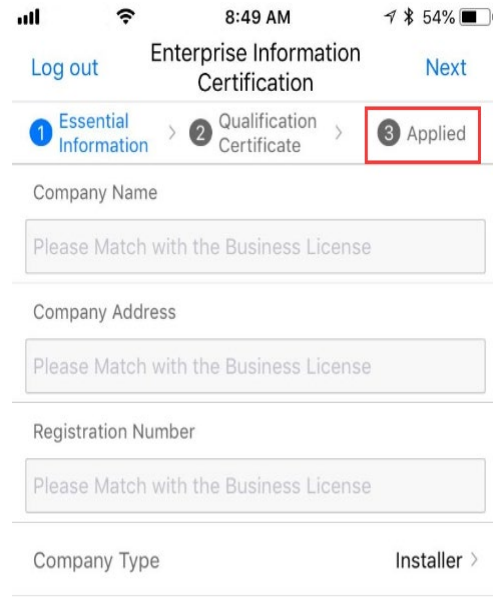
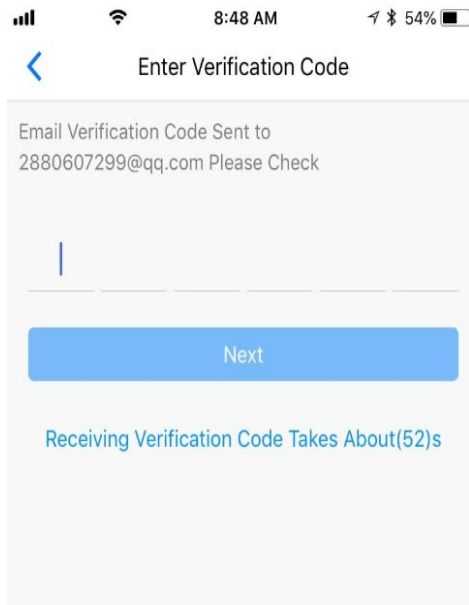

**Login:** Click on [Log in] in the App home page, and enter your email and password.

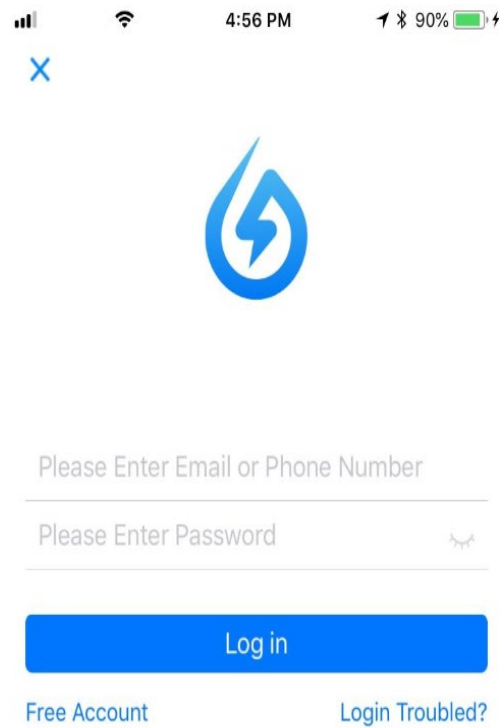
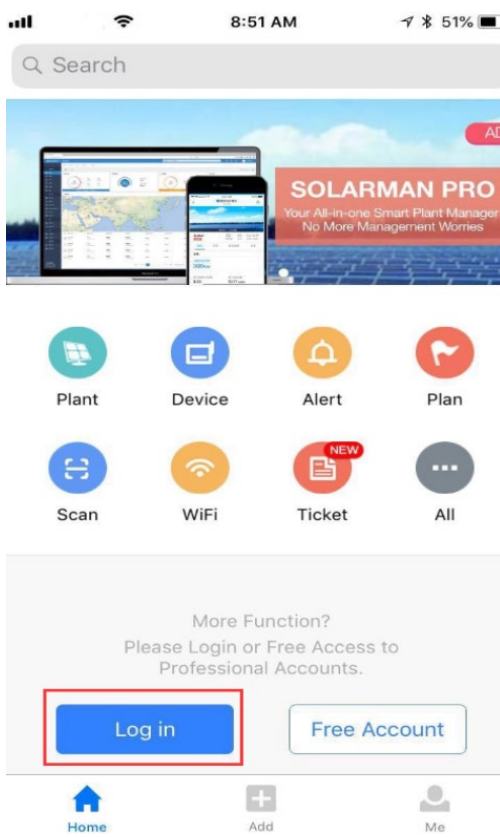



### 7.1.3 Create Plant

- Method 1: Click on [Add] in the App home page, and click the [Plant] icon from the pop-up menu, then scan the serial number of the stick logger.

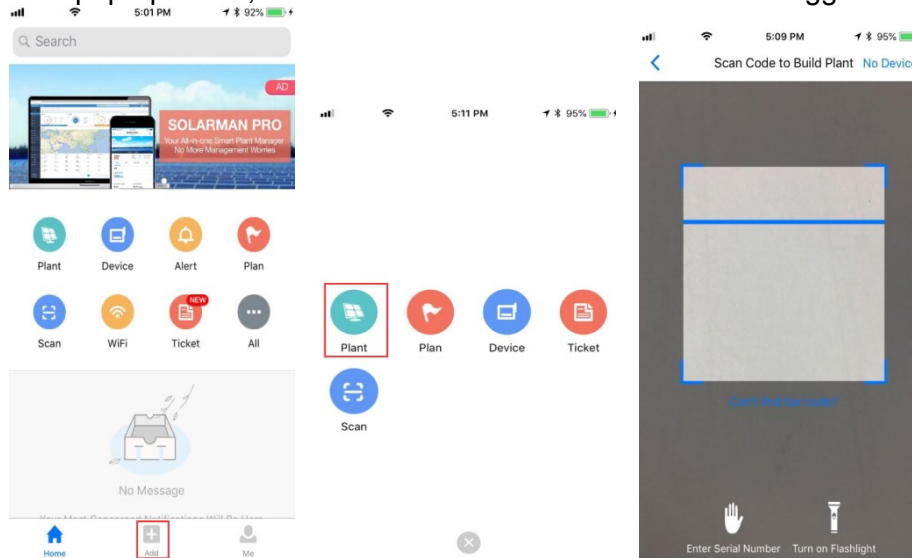

- Method 2: click the [Plant] icon first to enter the plant list, then click [+] in the upper right corner to add the plant, then scan the serial number of the stick logger.

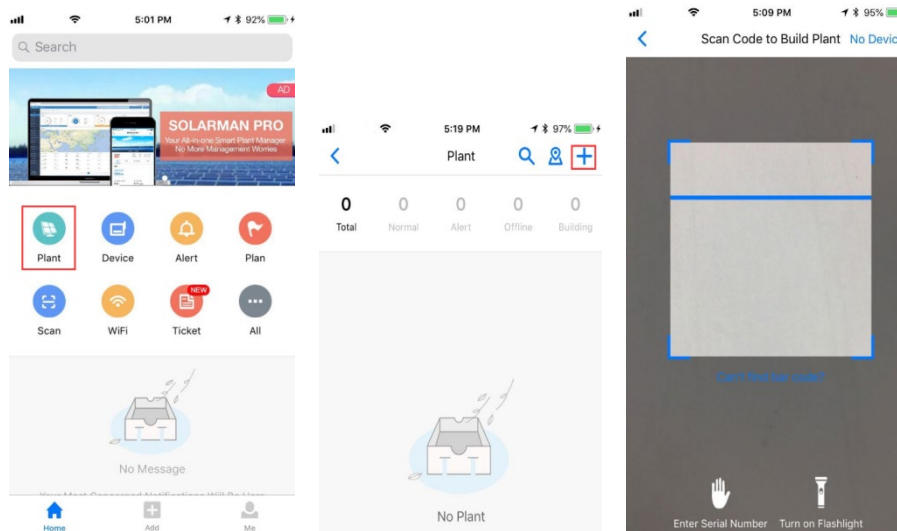

Note: If fail to scan by method 1 and method 2, you can manually enter the serial number.

#### 2. Edit the plant information

Enter the interface of plant information after successfully scanning the serial number or clicking on [No Device].

Confirm your plant location. GPS function will automatically locate the plant site. If you are absent at the scene of the plant, or want to modify the location, click the [map] icon to find the correct plant location.

Select your plant type.

Select your grid type.

Fill in plant capacity.

(You may keep the default settings in the rest of blank because App has received local electricity prices and subsidies)

Back Ensure Plant Information Next

Plant Location

Longitude 113°54'24"  
Latitude 22°58'5"

LOC Map

Plant Address

NO. No.6 Building B Gongye North Road Gu...

Plant Type

Home Industrial Business Utility

On-grid Type

Distributed Rest Power on Grid Distributed All Power on Grid

Ground Plant All Power on Grid Offline Storage System

Capacity(kWp) 5

3. Enter the plant name. It is suggested to create a plant name like "location + name + capacity", then click on [Done].

Back Enter Plant Name Done

Please Enter Plant Name

Contact(to contact owners)

4. Then the plant you added is shown on the homepage.

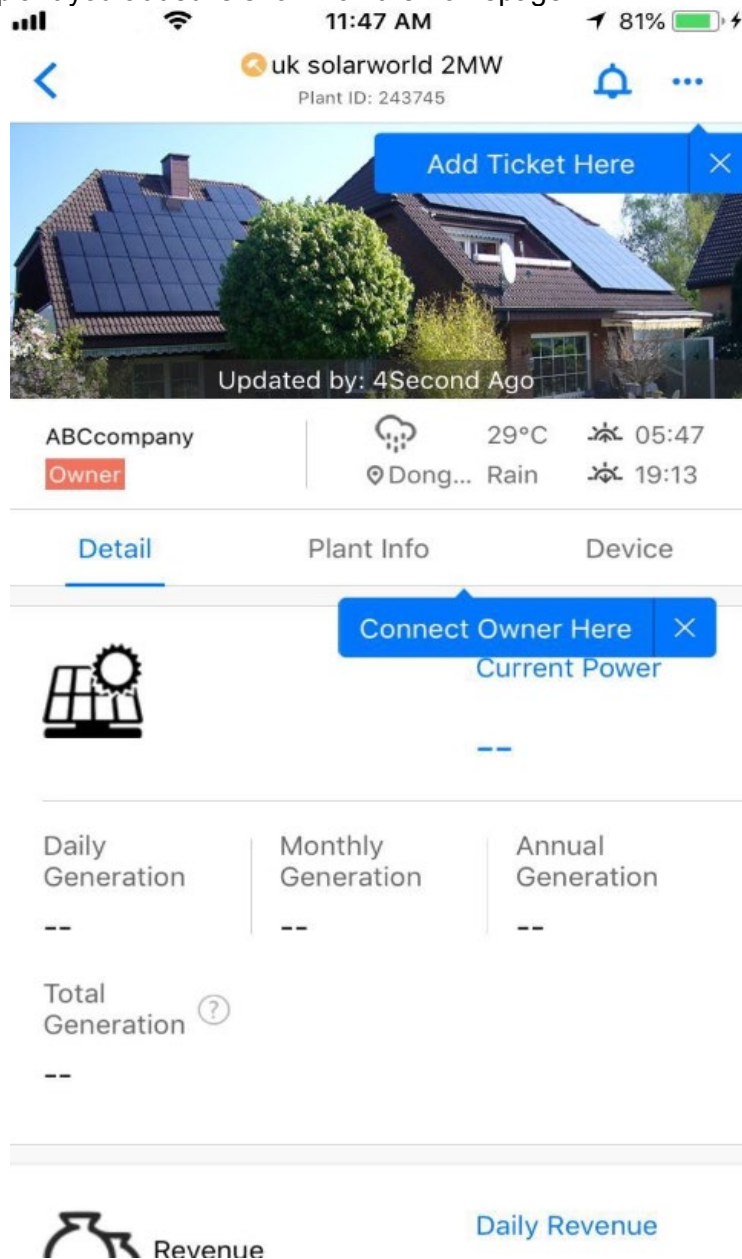

## 7.2 Home Edition App

Home edition APP is mainly used for residential PV system. It collects power generation information and operation information to enable users to obtain the running status information of the inverter in time.

### 7.2.1 Software Installation

Search "solarman" in Apple Store to download the App for iPhones, Search "solarman" in Google Play to download the App for Android phones.

### 7.2.2 Registration & Login

Click on [Register] to create new account, and enter your email to register.

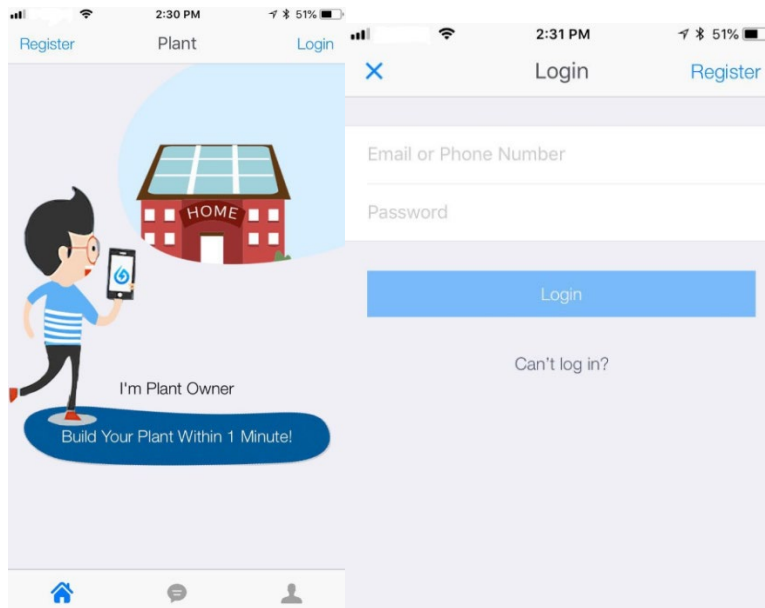

### 7.2.3 Create Plant

1. After login, click [+] in the upper right corner and follow the on-screen instructions. Then scan the serial number of the stick logger, or manually enter the serial number.

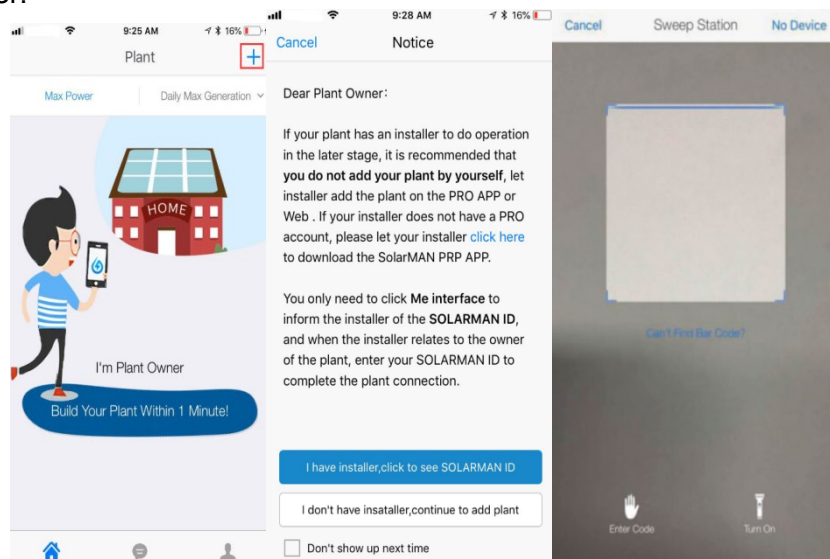

2. Edit Plant Information
  - Confirm your plant location. GPS function will automatically locate the plant site.
    - If you want to modify the location, click the [map] icon , and then manually enter the plant address.
  - Select your plant type.
  - Select your grid type.
  - Fill in plant capacity.
    - (You may keep the default settings in the rest of blank because App has received local electricity prices and subsidies)

Back Confirm Plant Info Next

Plant Location **1**

Longitude 120°21'37"

Latitude 31°30'23"

Plant Address

Tian'an Intelligent Park A3 Industrial Building Tian... **b**

Plant Type **2**

Resi Roof Industrial Commercial Utility

Grid Type **3**

Distributed Self Use Left on Grid Distributed All Power on Grid

Ground All Power on Grid Offline Storage System

Capacity(kWp) **4** 5

Directions

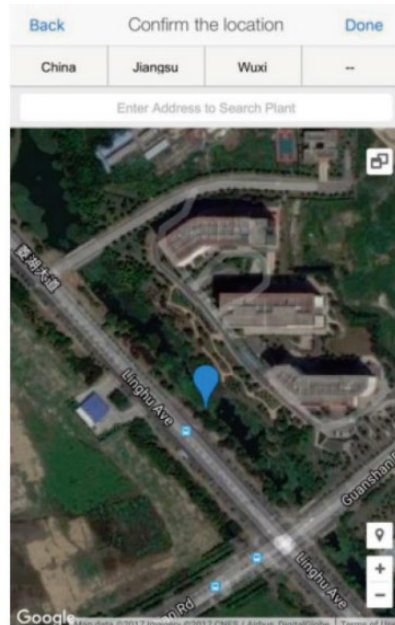

3. Enter the plant name. It is suggested to create a plant name like "location + name + capacity", then click on [Done].

11:00 AM 62%

Back Enter Plant Name Done

Please Enter Plant Name

Contact(to contact owners)

4. Then the plant you added is listed on the homepage.

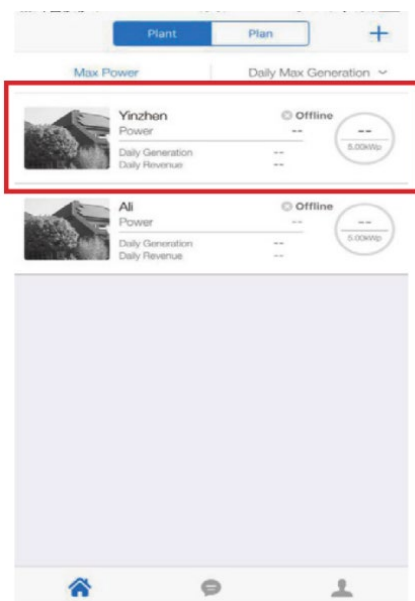

## 8. Removal of Common Faults

Fault information	Instructions	Recommendation
Grid overvoltage/ under-voltage	The voltage of AC side exceeds the allowed range	1. If occasionally, restart after the automatic recovery, and if frequently, adjust the protection parameters with the consent of the power grid company.
Grid over-frequency/ under-frequency	The frequency of AC side exceeds allowable range	2. If it cannot be recovered for a long time, check that the AC circuit breaker and output cable are properly connected. 3. Contact the installer and maintainer or manufacturer for help if the problem persists for a long time.
Off-grid	The AC side is not reliably connected to the grid or the grid is disconnected, and voltage cannot be detected	1. Check the connection of the AC circuit breaker and the AC terminal, and restart after the automatic recovery in case of grid failure. 2. Contact the installer and maintainer or manufacturer for help if the problem persists for a long time.
PV reverse connection	The positive and negative terminals of DC input PV1 or PV2 are reversed	1. Check whether the positive and negative terminals of the corresponding photovoltaic string are reversed. If yes, change “DCSWITCH” to “OFF” to adjust the polarity of the string after the solar irradiance decreases at night and the voltage of photovoltaic string falls within the safe voltage range (i.e. less than 36V DC). 2. In case of no above mentioned conditions, contact the installer and maintainer or manufacturer for help
PV overvoltage	DC input voltage is too high	1. If occasionally, restart after the automatic recovery. 2. If frequently, the number of series connection PV strings must be reduced.
Insulation impedance failure	The earth impedance of the photovoltaic module is less than the allowed value	1 Check the connection between the PV array and the ground wire, then restart the inverter (turn off the DC switch, wait 30 seconds, then turn it on). 2. Contact the installer and maintainer or manufacturer for help if the problem persists for a long time.
Abnormal leakage current	The leakage current exceeds allowable value	1. Check the connection between the PV array and the ground wire, then restart the inverter 2. Contact the installer and maintainer or manufacturer for help if the problem persists for a long time.

## 9. Appendix

### 9.1 Packing List

Check the inverter according to the following packing list. In case of any damage or shortage, contact the distributor.

No.	Name	Quantity/unit
A	Photovoltaic grid-connected inverter	1 piece
B	PV input terminal	6 sets (33KW) 5 sets (25-30KW) 4 sets (20KW)
C	AC output terminal	1 piece
D	Mounting bracket	1 piece
E	Expansion screws	3 pieces
F	Hex socket screws	2 pieces
G	Cross outer hexagonal double-pad screws	5 pieces
H	User manual	1 copy
I	Quick installation guide	1 copy
J	Communication module (485 or WIFI or GPRS)	1 piece
K	Waterproof terminal	1 piece

### 9.2 Quality assurance

**Warranty period:** The warranty period of this product is 5 years. If otherwise stipulated in the contract, the warranty period shall be subject to the contract.

**Evidence:** when the warranty service is provided during the warranty period, the user is required to show the product invoice, and the product trademark shall be clearly visible, otherwise the warranty is invalid.

**Conditions:** in case of a product failure during the warranty period, we will freely repair or replace the product. The replaced product should be returned to us. If the inverter fails, reasonable time shall be provided us for the maintenance of the faulty inverter.

The company will have the right not to provide the warranty in case of the following circumstances:

1. Expiration of the warranty period of the inverter and components
2. Damage caused during transportation
3. Installation, modification or use that does not meet national standards
4. Use in very harsh conditions beyond those described in this manual
5. Failure or damage caused by installation, repair, modification or disassembly of the service agency and the personnel unacceptable to us
6. Inverter failure or damage caused for due to the use of non-standard parts or software, or

those other than our parts or software

7. Design, installation and use beyond relevant international standards
8. Damage caused by abnormal natural environment

When the user requests the maintenance service for the product failure caused by the above conditions, we may provide paid maintenance service after confirmation.

In case of change in the size and parameters of the product, our latest information shall prevail without prior notice.

### **9.3 Contact us**

If you have any questions about this product, please get in touch with us according to following contact information:

Production Base:

Tel.: 0769-22897777

Fax: 0769-22898866

Postal code: 523808

Address: No. 6, Northern Industry Road, Songshan Lake Sci.&Tech. Industrial Park, Dongguan, Guangdong, China

-----

International Business:

Tel.: 0769-22898801 22898802

Fax: 0769-87920552

Email: [eastups@eastups.com](mailto:eastups@eastups.com)

-----

Domestic Business:

Tel.: 400-700-1660 800-830-5625

Fax: 0769-87882853

Email: [eastups@eastups.com](mailto:eastups@eastups.com)

Technical support: [service@eastups.com](mailto:service@eastups.com)